

DETAIL 'A' PLAN VIEW

NOTE: 2 elements required. Only 1 shown for drawing simplicity.

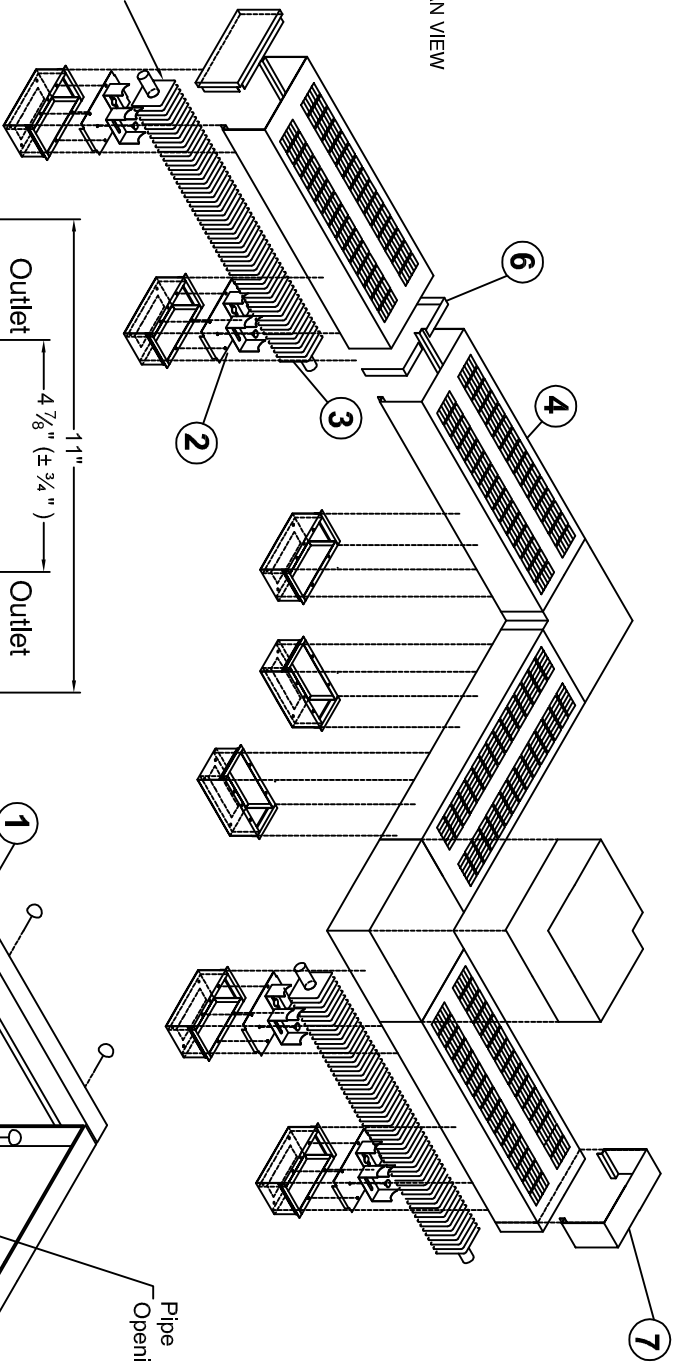

ELEMENT MODEL	DIM. X
3/4" Tube	6 1/2"
1" Tube	6 1/2"
1 1/4" Tube	6 3/4"

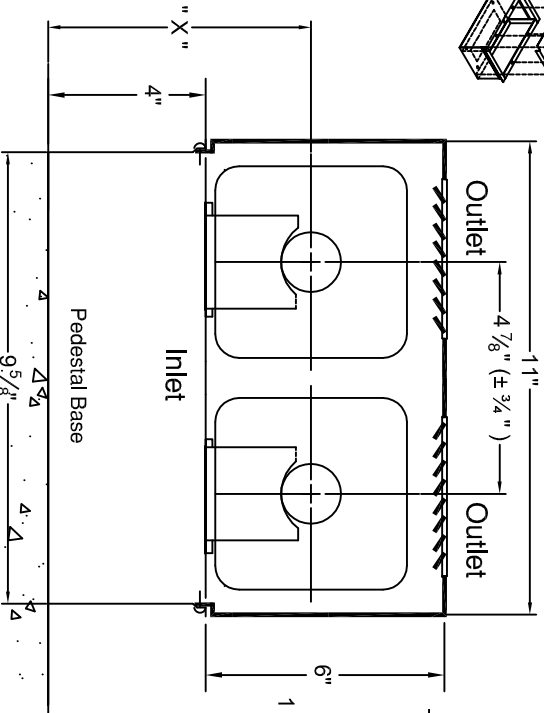

FLOOR

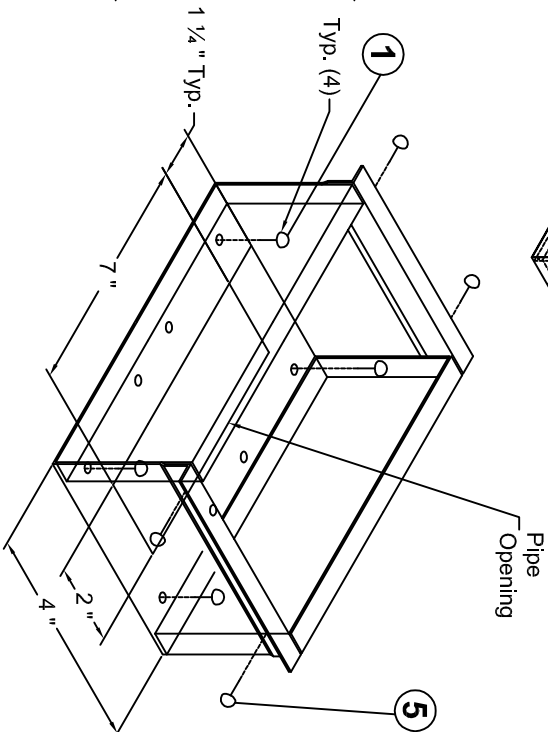

- ① Fasten pedestal base to floor at required distance from wall.
- ② Ensure pedestal bases are straight.
- ③ Fasten tops of pedestal base. Install cradles by placing cradle on pedestal base tops and insert the plastic fastener through the slot in the cradle into the hole in the pedestal top.
- ④ For 2 tier elements, mount and fasten additional tier brackets on top of pedestal base.
- ⑤ Install heating element onto element supports, ensure tubing rest in cradle.
- ⑥ Slide enclosure panel into pedestal base and screw bottom of panel on to the base.

- ⑦ For 2 or more side by side enclosure panels, join by an internal panel joiner (See Detail 'A'). Panel Joiners are made as 2 'L' shaped halves. If an access panel is used, join access panel to enclosure panel by a joiner strip and an additional pedestal base. (not shown)
 - ⑧ For trims and corners, slide down over enclosure and snap bottom of trim and/or corner on to bottom of enclosure and fasten with #10 screws.
- Note: all fasteners to be provided by the installing contractor.