

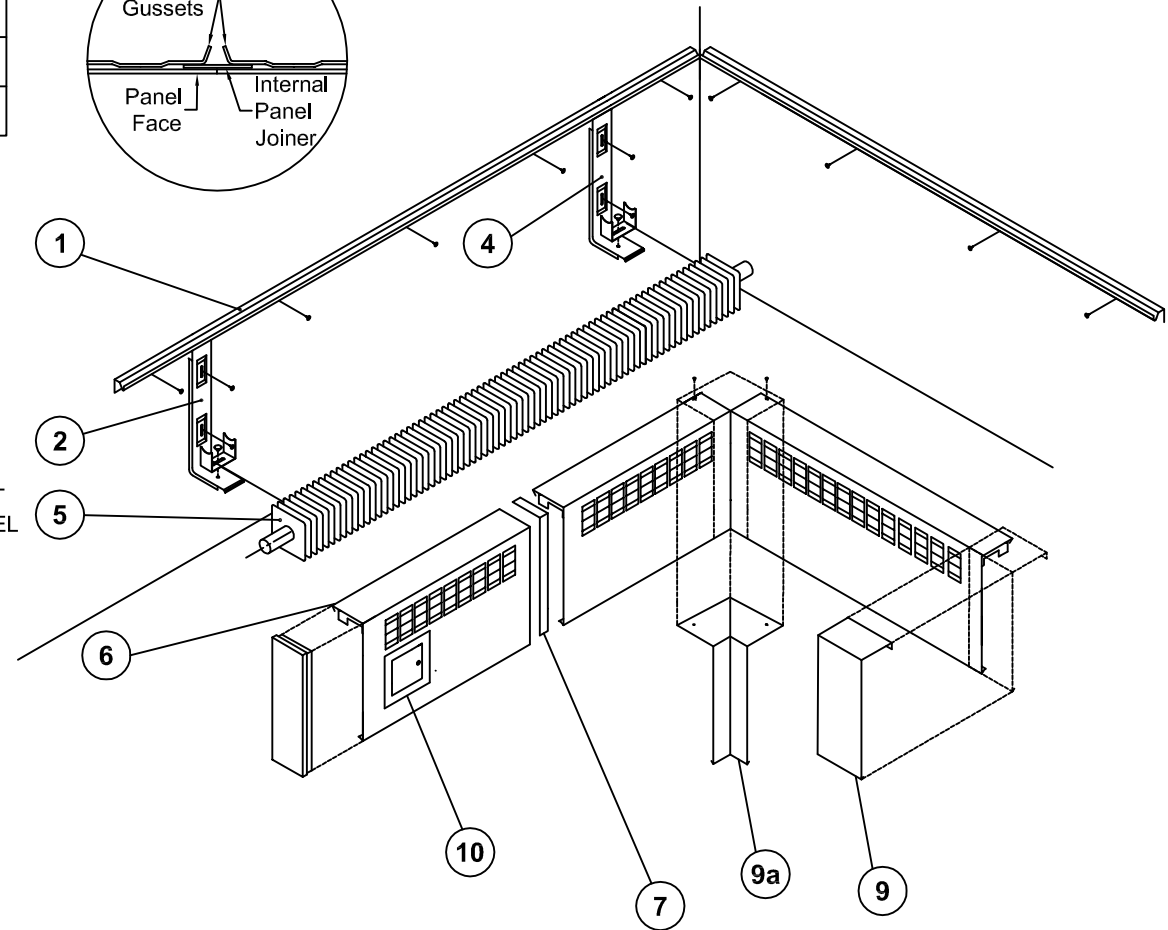

ELEMENT MODEL	DIM. X
3/4" Tube	2 3/4"
1" Tube	3"
1 1/4" Tube	3"

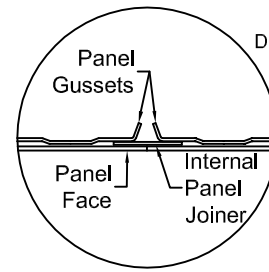
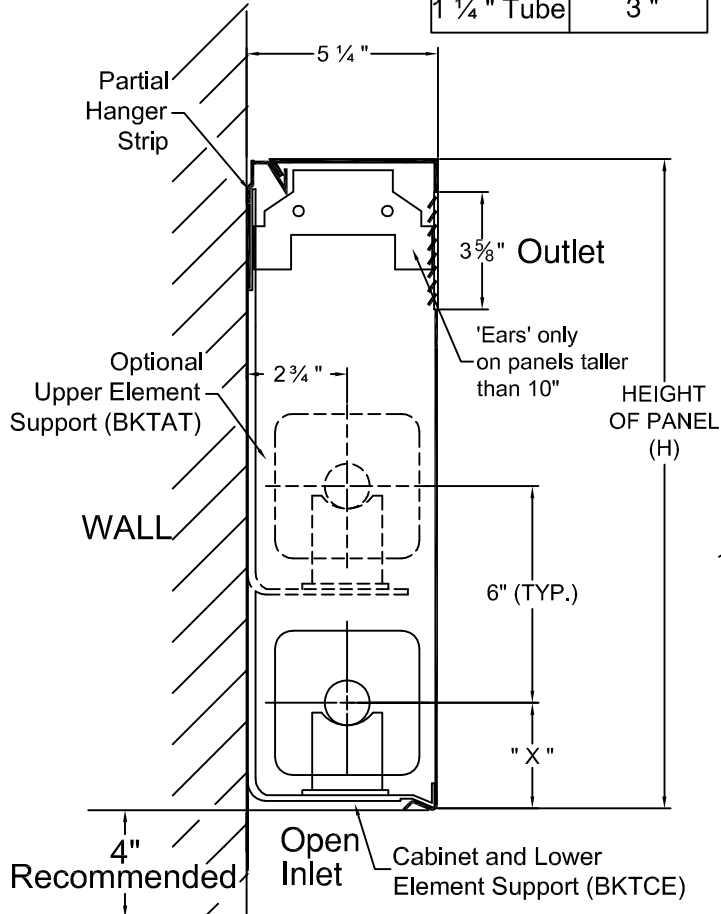

Additional tiers of element
only available on enclosure
12" and taller

- ① Fasten hanger strip to wall at required height. Ensure strip is level and that the hanger strip runs the entire length of the enclosure.
- ② Mount BKTCE brackets flush to and under the hanger strip.
- ③ For 2 tier elements, mount and fasten BKTAT brackets on to the BKTCE brackets.
- ④ Install cradles onto brackets by placing cradle on bracket and insert the plastic fastener through the slot in the cradle into the hole in the bracket.
- ⑤ Install heating element onto BKTCE brackets (and BKTAT brackets if used). Ensure tubing rests on cradle.

- ⑥ Place top of enclosure panel onto hangerstrip and snap bottom of panel onto the BKTCE bracket.
- ⑦ For 2 or more side by side enclosure panels, join by an internal panel joiner. (See Detail 'A')
- ⑧ If an access panel is used, join access panel to enclosure panel by a joiner strip and an additional mounting bracket. (not shown)
- ⑨ Hook bottom of trim strip on bottom of enclosure panel, swing trim up and hook top of trim on to the top of enclosure/hanger strip. For corners (9a) fasten at top by #10 screws.
- ⑩ If an access door is required, locate it on enclosure panel, cut out a 5 1/2" square opening and drill four 1/4" diameter holes on corners of 6 1/2" square. Mount and fasten access door assembly.