

## ACCESS PANEL WITH ACCESS DOOR ( SWE-S type enclosure shown for example )

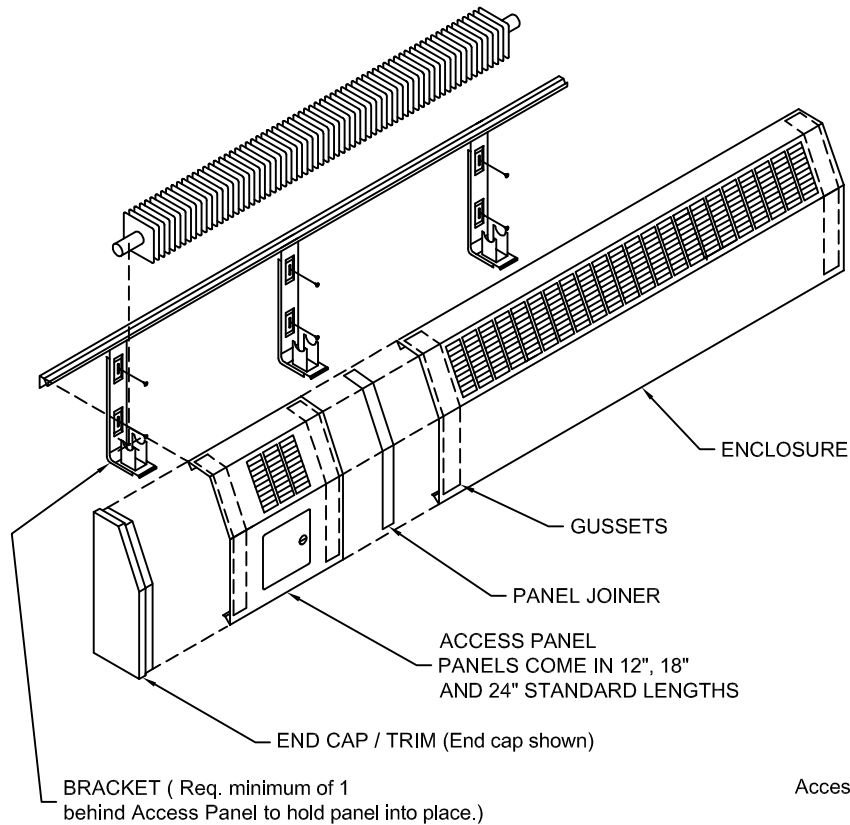

### INSTALLATION NOTES:

- 1) Slide panel joiner into adjacent enclosure.
- 2) Hook top of Access Panel into Hanger Strip, then swing downward and snap onto enclosure bracket(s).
- 3) Slide Access Panel up against adjacent enclosure making sure that the Panel Joiner is completely inserted into both the Access Panel and the adjacent enclosure.
- 4) Install End Cap / Trim onto end of Access Panel.



INSTALLED DETAIL (View from above)

NOTE: All fasteners to be supplied by others.

	Manufacturers of Hydronic Heating Products 6185 Kestrel Road, Mississauga, Ontario, Canada, L5T 1Z2 Tel: 905-670-3200, Fax: 905-670-3822	PLOT SCALE: NTS	PROJECT:	<h3 style="margin: 0;">ENCLOSURE DETAIL LAYOUT OF ACCESS PANEL C/W ACCESS DOOR</h3>				
	DO NOT SCALE PRINT	DRWN: R DATE: 02/09/16	ARCH.:					
	DIMENSIONS ARE IN INCHES UNLESS OTHERWISE SPECIFIED	REVISION 0	ENG.:					
			OUR FILE:					
ACCESS PANEL-ASSY-03				<table border="1" style="border-collapse: collapse;"> <tr> <td style="font-size: xx-small;">SHEET</td> <td style="font-size: xx-small;">NEXT</td> </tr> <tr> <td style="text-align: center;">1</td> <td style="text-align: center;">1</td> </tr> </table>	SHEET	NEXT	1	1
SHEET	NEXT							
1	1							